

ELVORON HOME ELEVATOR

DESIGN AND PLANNING GUIDE

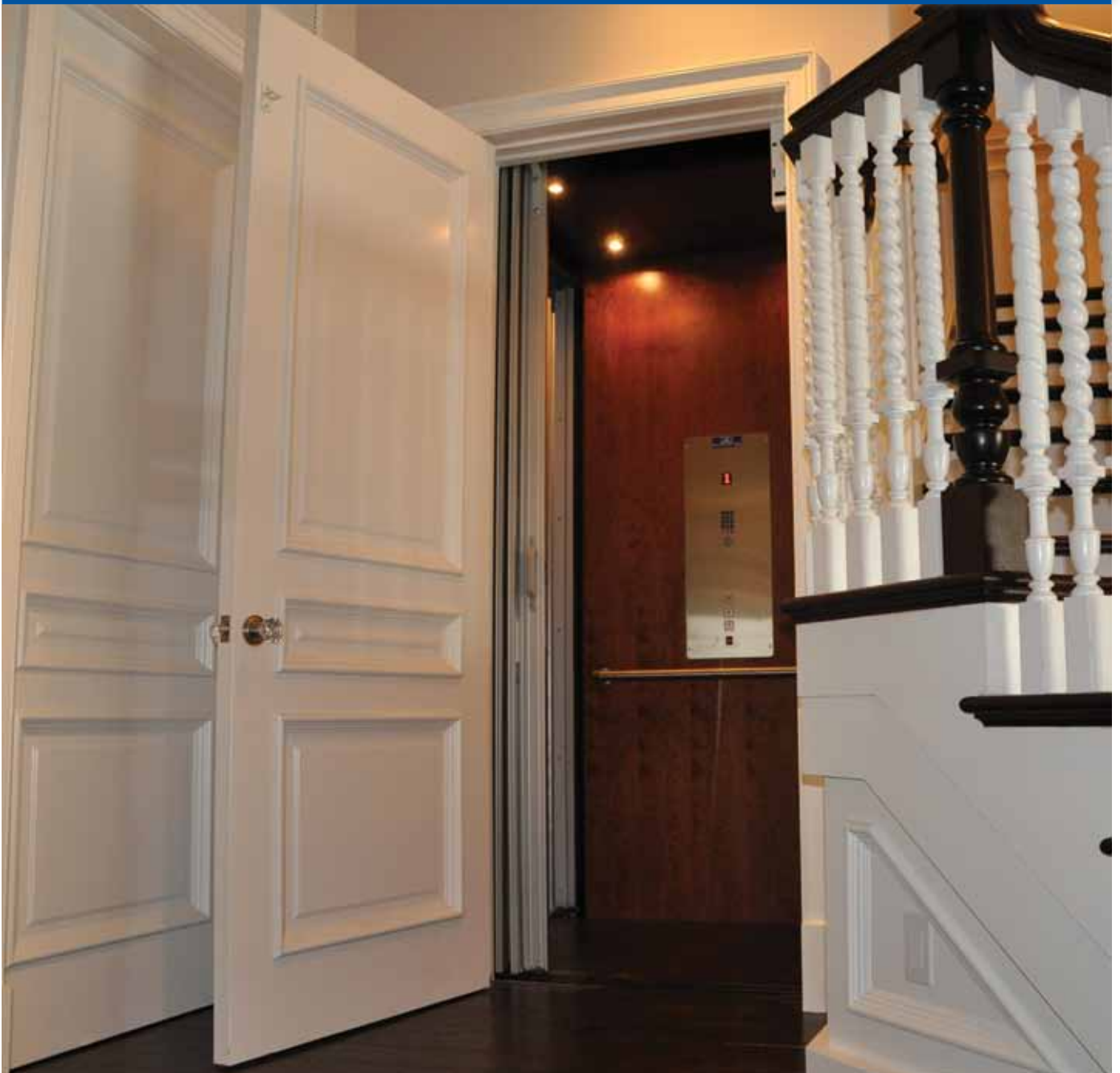

Please note:

Dimensions provided in this Guide are for **REFERENCE ONLY** and should not be used for site preparation or construction.

Elvoron Home Elevator Table of Contents

Elvoron - Home Elevator	2
Hoistway Construction	3
Wood Construction	4
Masonry Construction	4
Door Openings	4
Construction of Pit:	5
Pit Lighting	5
Overhead Clearance	5
Hoistway Doors	6
Hoistway Door Interlock	6
Automatic Cab Gate (Optional)	6
Hall Door Operator (Optional)	6
Loading Diagram:	7
On / Off Same Side Configuration Style 1:	8
Straight Through Configuration Style 2:	9
90° Entry / Exit Configuration Style 3 & 4:	10
On / Off Same Side Configuration Style 5:	11
Hydraulic Drive System Overview:	12
Hydraulic Drive System - Technical Reference:	13
General	13
Equipment	13
Controls	13
Safety Features	13
Options	13
Hydraulic Drive System - Machine Room & Electrical Requirements:	14
Electrical Disconnects	15
Ventilation Requirements	15
Mains Power Requirements	15
Lighting Power Requirements.....	15
Emergency Battery Lowering	15
Emergency Manual Lowering	15
Drive System - Machine Room & Electrical Requirements:	16
In-line Drive System Overview	17
In-line Drive System - Technical Reference:	18
General	18
Equipment	18
Controls	18
Safety Features	18
Options	18
In-line Drive System - Electrical Controller Box Details & Locations	19
Electrical Disconnects	20
Ventilation Requirements	20
Mains Power Requirements	20
Lighting Power Requirements.....	20
Battery Lowering - Optional	20
Battery Backup - Optional	20
Emergency Lowering - Standard	21

Elvora - Home Elevator

The Elvora is a sophisticated elevating system designed specifically for use in private residences. The system fits within a vertical elevator hoistway connecting the floors to be serviced. Two different drive systems are available with your elevator, the Hydraulic Drive and the In-line Drive.

This Design Guide is intended to assist architects, contractors, home owners and elevator professionals in planning for the Elvora Home Elevator installation. We strongly recommend that you contact your local Garaventa Lift representative to discuss and become familiar with the code requirements in your area. It is extremely important for you to know and adhere to all local codes and regulations pertaining to the installation and use of residential elevators.

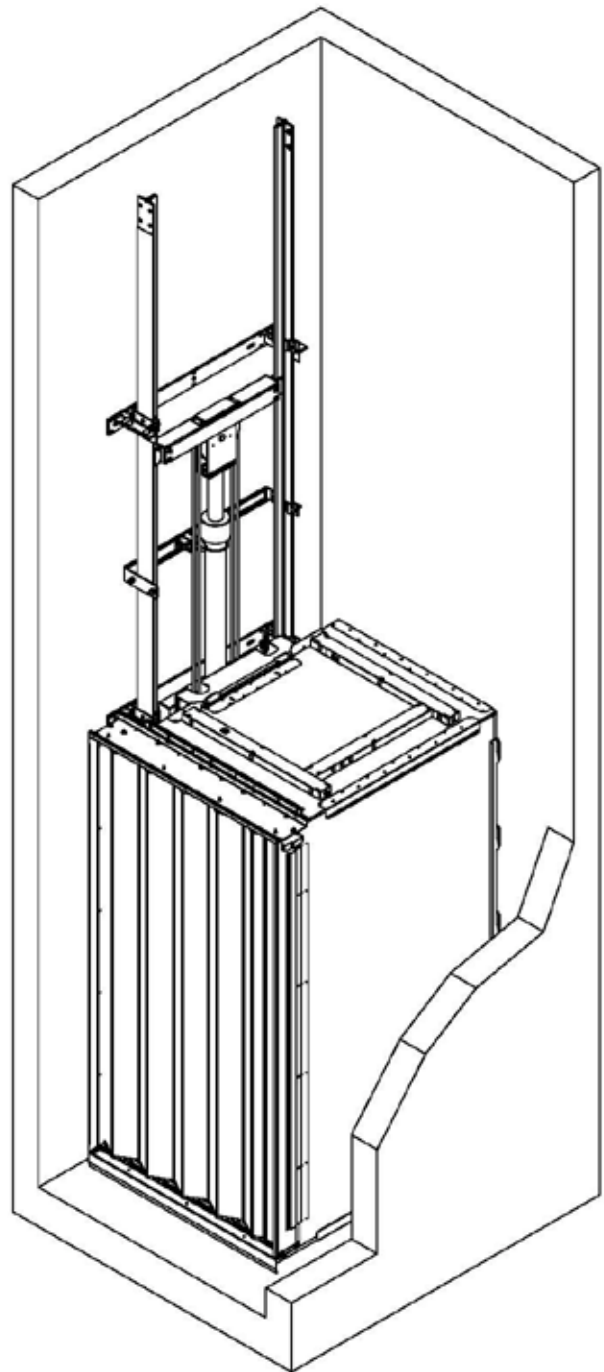

Hydraulic Drive System Shown

Hoistway Construction

The elevator rails are attached to a load bearing wall using rail brackets. The rail bracket spacing is determined during the design phase. The rail brackets are generally 4' to 8' apart, measured vertically, depending on the load capacity, size of cab and travel height. Hoistway construction shown is suitable for both the Hydraulic Drive system and the In-line Drive system. Please see final elevator shop drawings for actual rail bracket locations and job specific dimensions.

All the walls of the hoistway, especially the supporting wall, need to be smooth, square and plumb from the bottom of the pit to ceiling. This is to allow for the required running clearances.

No light is required at the top of the hoistway. A light is required in the pit (see Construction of Pit for details).

Hydraulic Drive System Shown

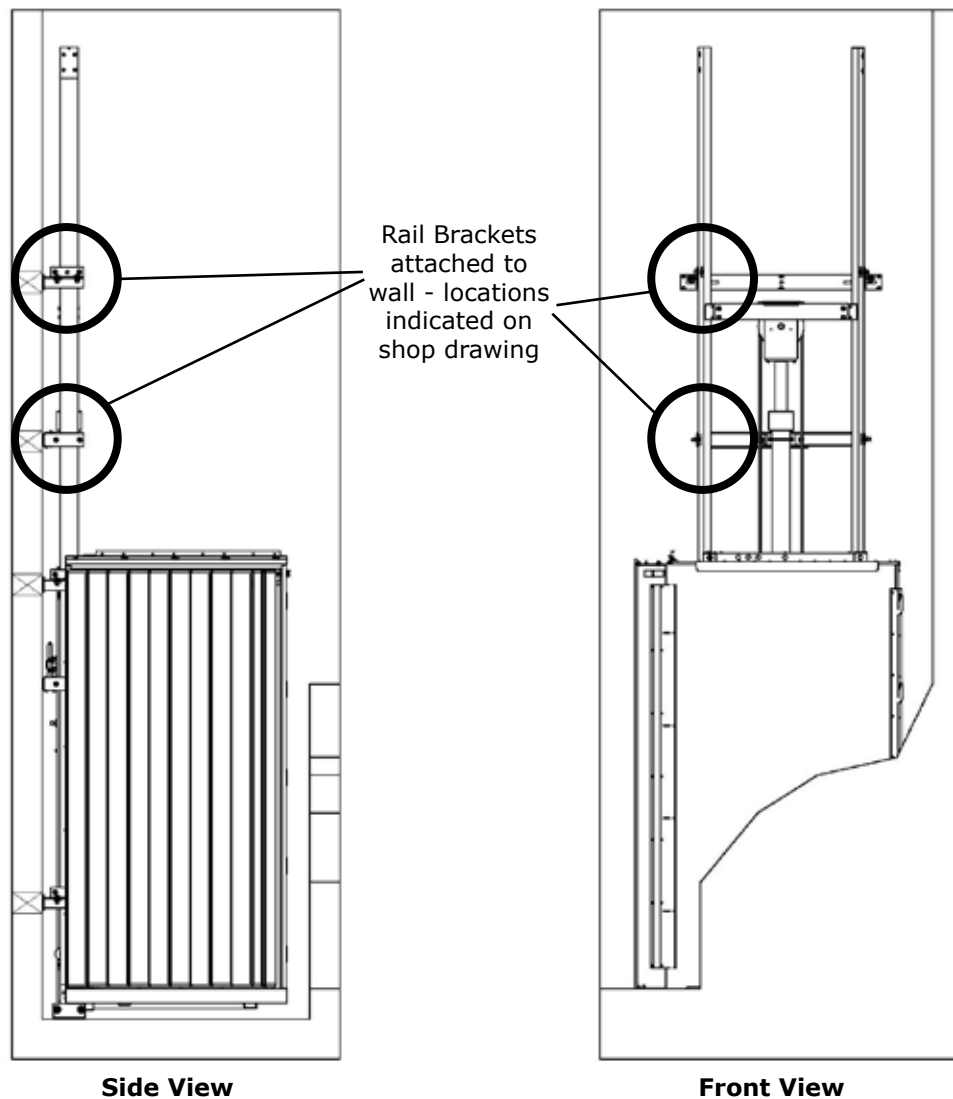

Wood Construction

2" x 4" wood studs should be used, 2" x 12"s laid flat are then fastened between the studs. Consult with your local Garaventa Lift representative if you plan on using wood studs larger than 2" x 4", as this can affect clearances controlled by code.

The hoistway dimensions indicate the clear inside finished hoistway. Please ensure you allow for wall finishing (plywood/drywall) on top of the studs.

Masonry Construction

It is not necessary to make the return walls on either side of the doors in concrete. More flexibility in door positioning during the installation can be achieved with wood framing around hoistway entrances.

Door Openings

Garaventa Lift recommends that the walls on either side of the hoistway entrances be framed and finished after the doors and frames have been aligned on site. However a header frame above the door will be required to mount the door in place.

During installation the rails system and floor of the cab are installed, then the doors are aligned to the centerline of the cab opening.

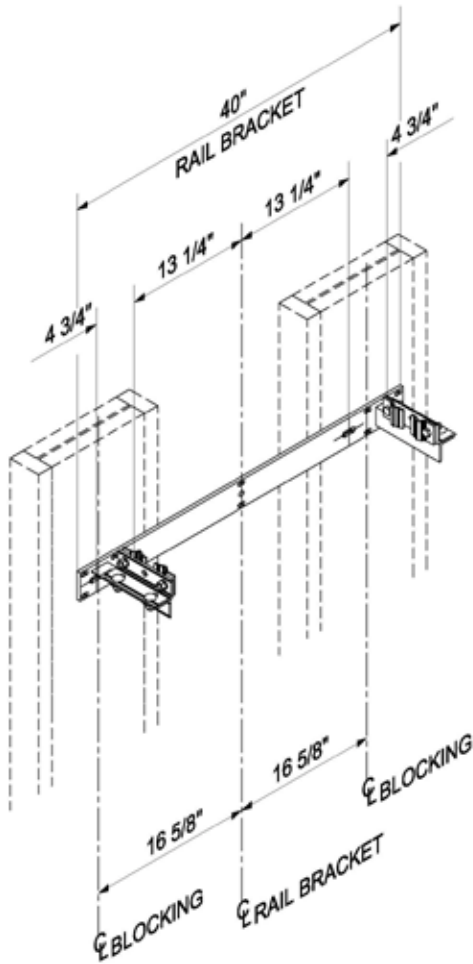

Wood Blocking Guidelines

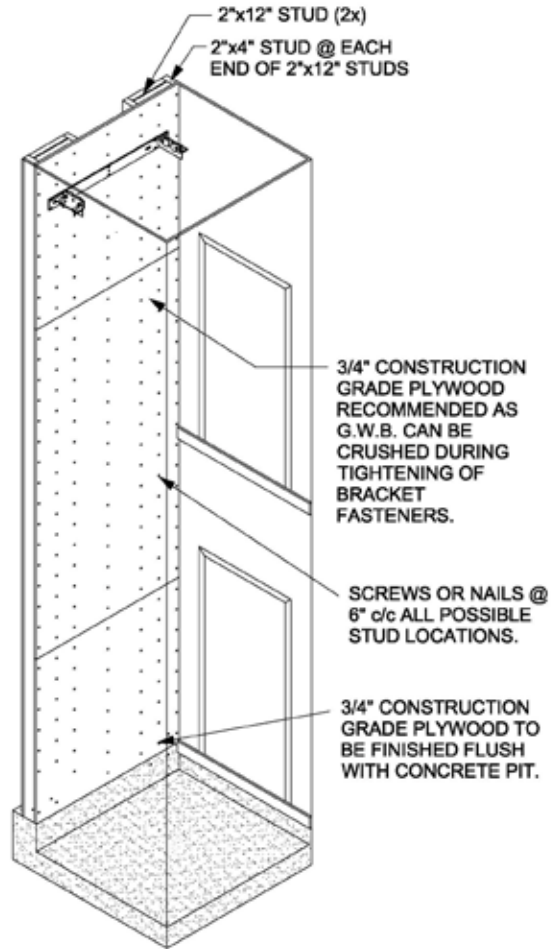

Rail Bracket in Hoistway

Construction of Pit:

The pit must be the same width and length as the hoistway, and should have a minimum 4" thick concrete floor. Reactions are indicated on each floor. A pit depth of 8" (200 mm) is recommended, a 6" (152 mm) pit depth is available, contact Garaventa Lift for details*.

A pit ladder is required only if the pit depth exceeds 3' (900 mm). Consult your Garaventa Lift representative for details as changes to the finished hoistway size maybe required.

Pit Lighting

A pit light is required if the lighting is less than 50 lx at the pit floor with the lowest door open. The general contractor can install a light in the hoistway pit or provide a separate 110v duplex receptacle outside the hoistway, within 10' (3000 mm) of either side of the lowest landing door.

Overhead Clearance

84" (2134 mm) Cab Height - Standard

- 96" (2440 mm) is required from top landing to the ceiling of hoistway

If an In-line Drive system is used and the electrical control box is located at the top of the hoistway, extra overhead clearance is required, 108" (2745 mm)

96" (2438 mm) Cab Height

- 108" (2745 mm) is required from top landing to the ceiling of hoistway

If an In-line Drive system is used and the electrical control box is located at the top of the hoistway, extra overhead clearance is required, 120" (3050 mm)

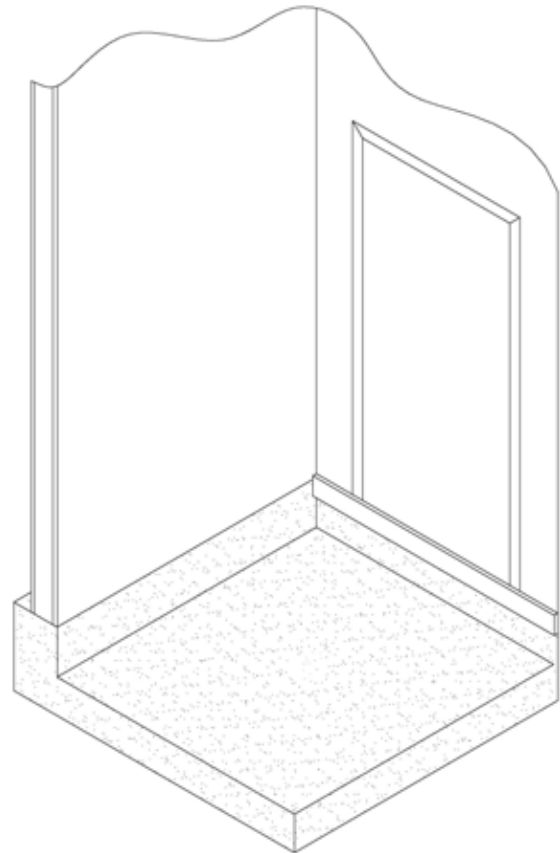

*Larger cabs can require up to a 12" (305mm) pit.

Hoistway Doors

Residential solid core doors must be used as the hoistway doors for the elevator. The doors are equipped with an interlock, during installation, to lock the doors when the elevator is not present at that landing.

The doors need to comply with the "3 & 5 Rule" which references the positioning of the door in relation to the elevator hoistway (see drawing).

Automatic Cab Gate (Optional)

The cab gate(s) can be equipped with a power operator for automatic gate opening and closing when the cab arrives at a landing or the landing door is opened.

Hall Door Operator (Optional)

Each hall door may be supplied with a power door operator. This feature will open the landing door when the cab arrives at a landing or when the hall station is pressed. The operator is mounted above the door frame and requires extra support or blocking and a separate 110 VAC power supply above the door header.



Hoistway Door Interlock

The hoistway door is fitted with an interlock that ensures the car can not be moved from a landing unless all the hall doors and cab gate(s) are both closed and locked.

3" & 5" Door & Gate Rule

The clearance between the hoistway doors or gates and the hoistway edge of the landing sill shall not exceed 3" (76mm). The distance between the hoistway face of the landing door or gate and the car door or gate shall not exceed 5" (127mm).

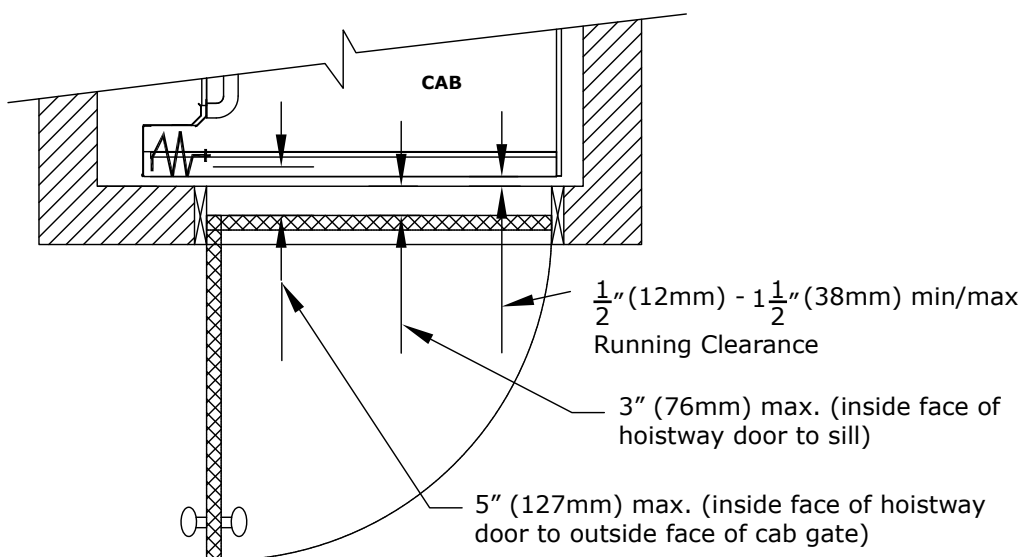

Loading Diagram

The walls of the elevator hoistway can be constructed of wood, poured concrete or concrete block. The wall behind the rails must be load bearing and able to withstand the loads imposed by the elevator.

The guide rails are mounted to the wall with steel brackets. These rail brackets are fastened to the load bearing wall at regular intervals. See shop drawings for locations.

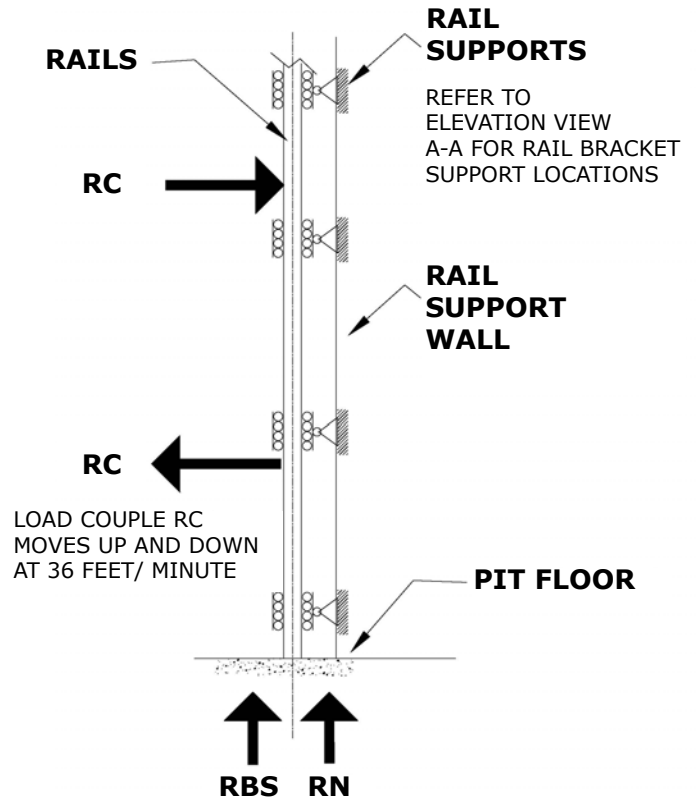
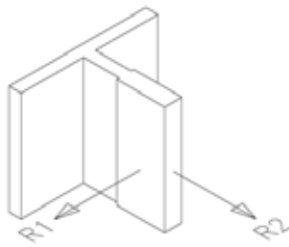

Load	Description	lbf [N]
RBS	Reaction due to buffer safety engagement	4569 [20321.74]
RN	Reaction due to normal operation	2619 [11647.71]
RC	Load imposed during normal or emergency operation maximum pull-out force on rail support	636 [2829.797]
R1	Rail Reaction	318 [1415]
R2	Rail Reaction	94 [420]

On / Off Same Side Configuration Style 1:

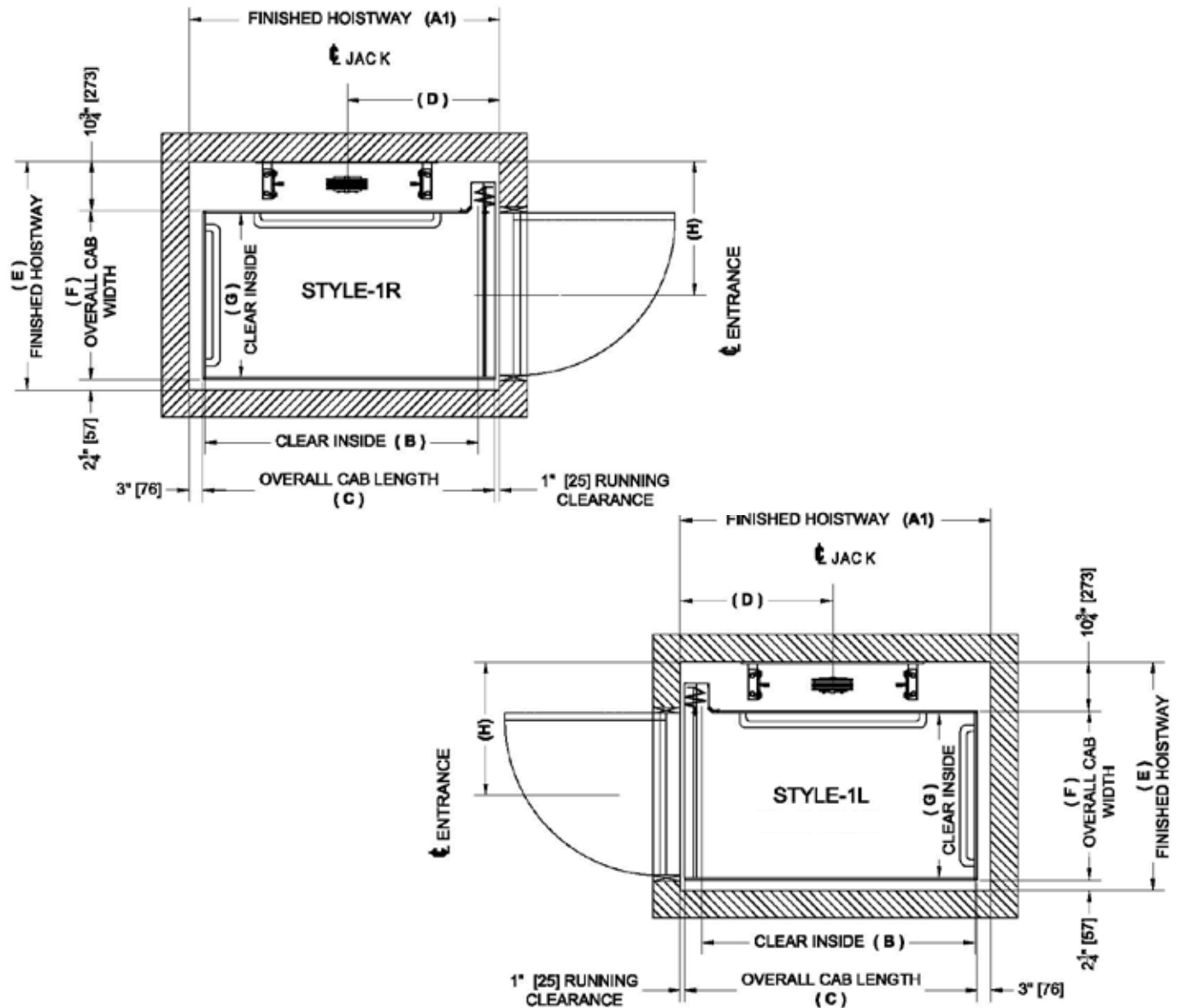

Cab Size	A1	B	C	D	E	F	G	H
36" x 48"	56 1/4"	48"	52 1/4"	30"	50"	37"	36"	29 1/4"
36" x 54"	62 1/4"	54"	58 1/4"	30"	50"	37"	36"	29 1/4"
36" x 60"	68 1/4"	60"	64 1/4"	33"	50"	37"	36"	29 1/4"
40" x 54"	62 1/4"	54"	58 1/4"	30"	54"	41"	40"	31 1/4"
* 42" x 60"	70 1/4"	60"	66 1/4"	36 5/8"	56"	43"	42"	35 1/4"
* 48" x 60"	70 1/4"	60"	66 1/4"	36 5/8"	62"	49"	48"	41 1/4"

*Cab sizes are limited to 15 sq. ft. in some areas. Consult with your local Garaventa Lift representative.

Straight Through Configuration Style 2:

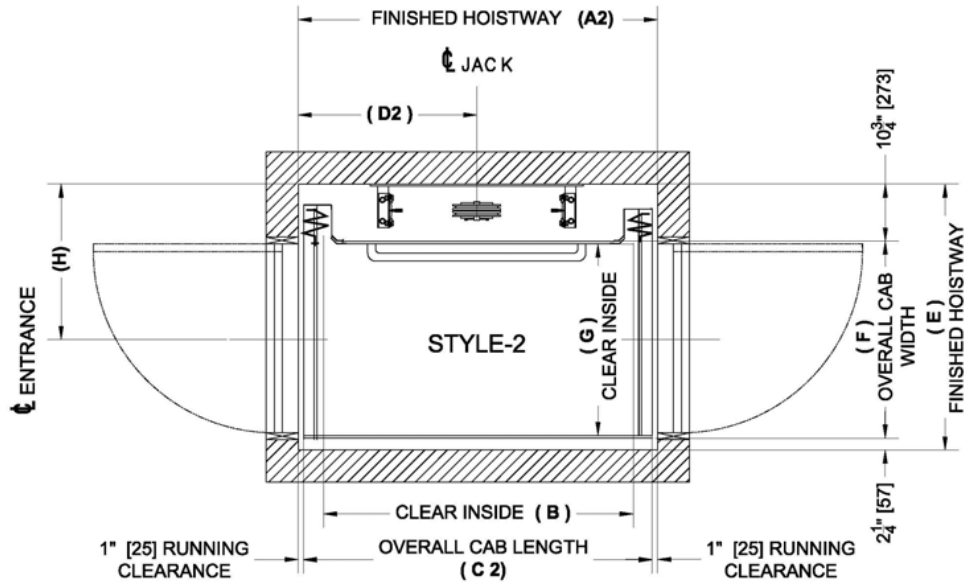

Cab Size	A2	B	C2	D2	E	F	G	H
36" x 48"	54 3/4"	48"	52 3/4"	27 3/8"	50"	37"	36"	29 1/4"
36" x 54"	60 3/4"	54"	58 3/4"	30 3/8"	50"	37"	36"	29 1/4"
36" x 60"	66 3/4"	60"	64 3/4"	33 3/8"	50"	37"	36"	29 1/4"
40" x 54"	60 3/4"	54"	58 3/4"	30 3/8"	54"	41"	40"	31 1/4"
* 42" x 60"	73 1/2"	60"	71 1/2"	36 3/4"	56"	43"	42"	35 1/4"
* 48" x 60"	73 1/2"	60"	71 1/2"	36 3/4"	62"	49"	48"	41 1/4"

*Cab sizes are limited to 15 sq. ft. in some areas. Consult with your local Garaventa Lift representative.

90° Entry / Exit Configuration Style 3 & 4:

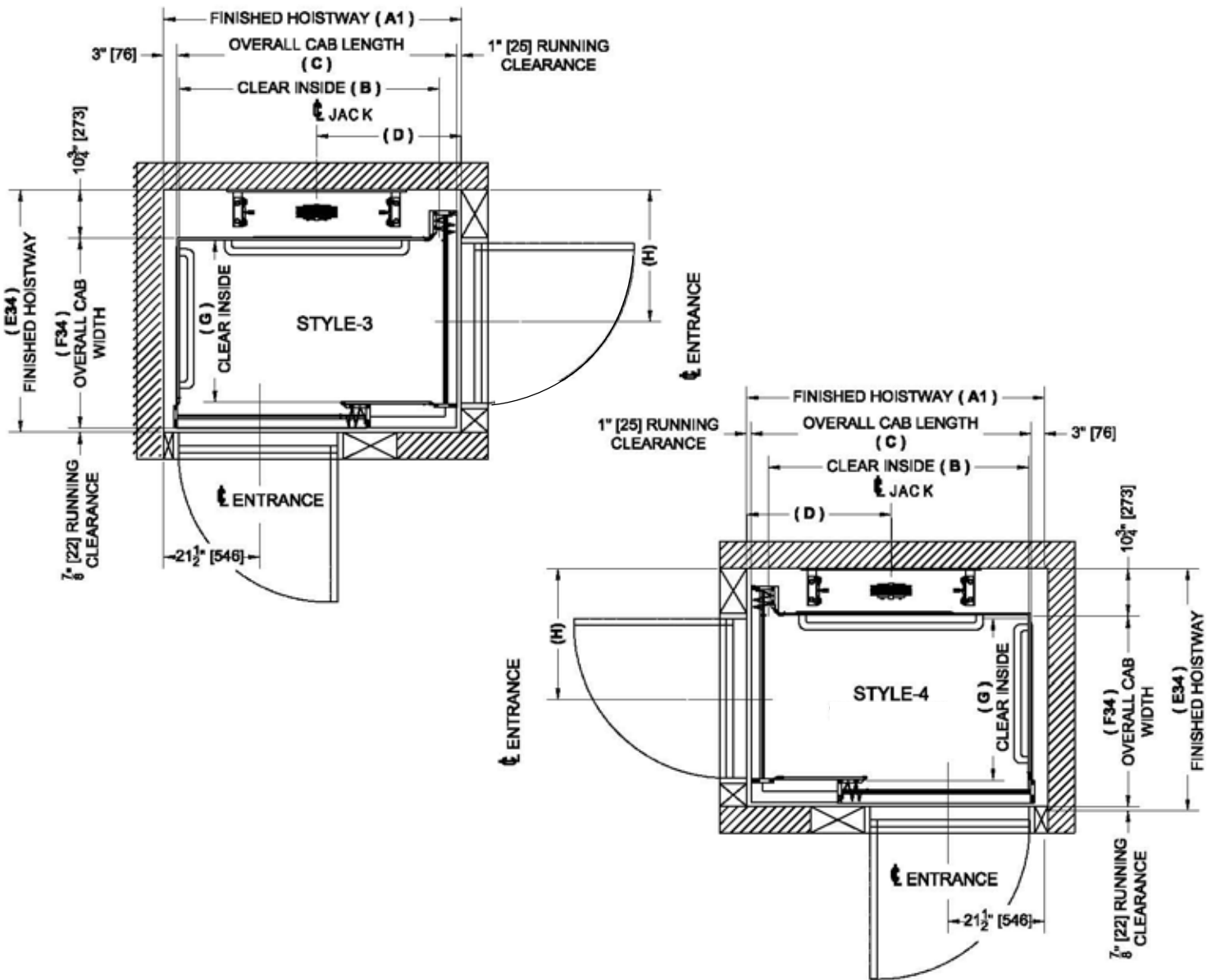

Cab Size	A1	B	C	D	E34	F34	G	H
36" x 48"	56 1/4"	48"	52 1/4"	30"	53 7/8"	42 1/4"	36"	29 1/4"
36" x 54"	62 1/4"	54"	58 1/4"	33"	53 7/8"	42 1/4"	36"	29 1/4"
36" x 60"	68 1/4"	60"	64 1/4"	36"	53 7/8"	42 1/4"	36"	29 1/4"
40" x 54"	62 1/4"	54"	58 1/4"	33"	57 7/8"	46 1/4"	40"	31 1/4"
* 42" x 60"	70 1/4"	60"	66 1/4"	36 5/8"	59 7/8"	48 1/4"	42"	38 1/4"
* 48" x 60"	70 1/4"	60"	66 1/4"	36 5/8"	65 7/8"	54 1/4"	48"	41 1/4"

*Cab sizes are limited to 15 sq. ft. in some areas. Consult with your local Garaventa Lift representative.

On / Off Same Side Front Configuration Style 5:

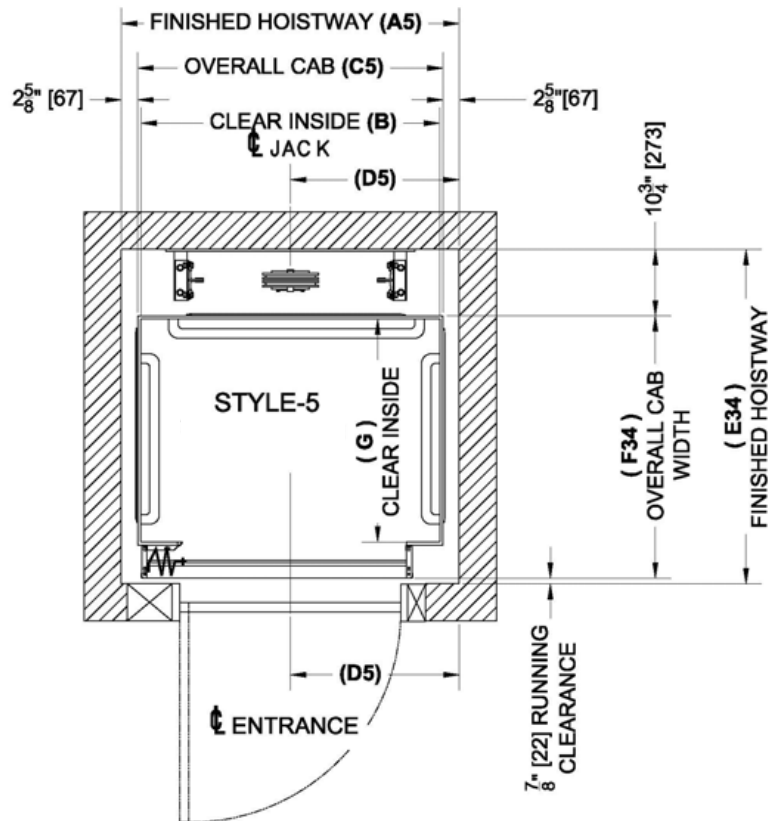

Cab Size	A5	B	C5	D5	E34	F34	G	H
36" x 48"	54 1/4"	48"	49"	27 1/8"	53 7/8"	42 1/4"	36"	27 1/8"
36" x 54"	60 1/4"	54"	55"	30 1/8"	53 7/8"	42 1/4"	36"	30 1/8"
36" x 60"	66 1/4"	60"	61"	33 1/8"	53 7/8"	42 1/4"	36"	33 1/8"
40" x 54"	60 1/4"	54"	55"	30 1/8"	57 7/8"	46 1/4"	40"	30 1/8"
* 42" x 60"	66 1/4"	60"	61"	33 1/8"	59 7/8"	48 1/4"	42"	33 1/8"
* 48" x 60"	66 1/4"	60"	61"	33 1/8"	65 7/8"	54 1/4"	48"	33 1/8"

*Cab sizes are limited to 15 sq. ft. in some areas. Consult with your local Garaventa Lift representative.

Hydraulic Drive System Overview:

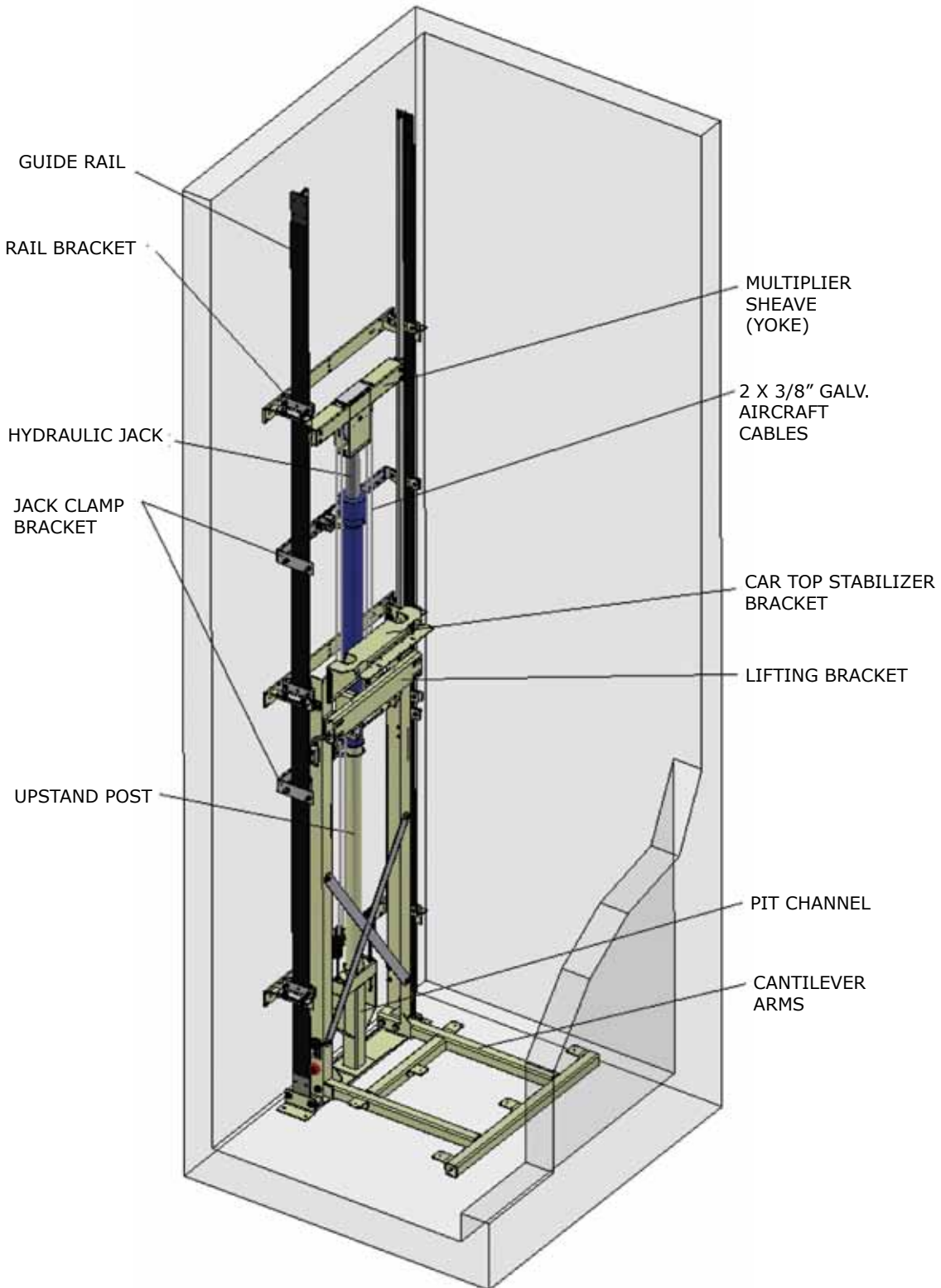

Hydraulic Drive System - Technical Reference:

General

- Capacity - 750 lbs or 1000 lbs with standard doors and gates, 1400 lbs. with automatic sliding doors
- 40' (12.2 M) per minute nominal car speed
- Up to 6 stops, Maximum 6 landing doors
- Maximum floor total travel of 50' (15.2 m) with standard swing doors or 32' (9.75 m) with automatic sliding doors. Reduced capacity of 1000 lbs. (455 kg) allows for 36' (10.9 m) of travel with sliding doors
- Pit depth of 8" (200 mm) is recommended for units with standard swing doors. 14" (356 mm) pit required for units with automatic sliding doors
- Overhead clearance of 96" (2440 mm) from upper landing with standard 84" (2135 mm) cab and swing doors. 135" (3429 mm) for units with automatic sliding doors
- Minimum distance between floors is 10" (255 mm)

Equipment

- Two speed control valve with soft start and stop
- 1:2 cable hydraulic drive
- Single stage Hydraulic drive with two 3/8" aircraft cables
- Heavy duty cantilever design utilizing 8 lbs per foot steel elevator guide rail system
- Submersible pump and motor assembly for quiet operation
- Standard power supply is 230 VAC single phase – 60/ 50 Hz. Optional 208 VAC three phase

Controls

- Collective automatic operation with illuminated push buttons
- PLC (Programmable Logic Controller) with backup system for lights, locks, gate and/or door operator(s) where equipped and elevator descent
- Digital position indicator in cab
- Automatic cab lighting
- Low oil protection timer circuit
- Emergency stop and alarm

Safety Features

- Emergency manual lowering
- Slack/broken cable instantaneous safety device
- Upper and Lower terminal limit switches and a Final limit at top and bottom of travel
- Hoistway door interlocks ensure the car does not move unless all hall doors and cab gate(s) are closed and locked
- Emergency battery backup light and alarm
- UL and/or CSA certified electrical control system
- Automatic bi-directional leveling (Encoder)
- Solid cab gates with safety switch

Options

- Pipe rupture valve
- Keyed hall stations
- Recessed telephone box or integrated telephone in cab control panel
- Automatic cab gate operator
- Automatic hoistway door operator
- Custom cab sizes and cab heights
- Buffer Springs – required for hoistways with habitable space under the pit

Hydraulic Drive System - Machine Room & Electrical Requirements

In order to satisfy code requirements, the hydraulic pump unit and fused disconnect switches must be located in a room or area which is lockable. A lockable cabinet is acceptable. However, to meet electrical code, Service Personnel must have the following clearance in front of the electrical box:

US - 36" x 36" x 7' (915 x 915 x 2135mm)

Canada - 39^{3/8}" x 39^{3/8}" x 7' (1000 x 1000 x 2135mm)

The machine room does not have to be a separate, dedicated room. The machinery could be located in a closet or under the stairs, as long as the above requirements are met. The optimum location is at the lowest level, adjacent to the hoistway, preferable on the same side as the guide rails. The dimensions of the pump unit are 23" wide x 16 1/2" deep x 59 1/4" high (585 x 420 x 1505 mm).

To save space the electrical control box can be disconnected from the tank. They can be separated up to 10' (3048 mm) away. The control box is 23" wide x 6" deep x 30" high (585 x 155 x 765 mm). The tank for the pump and motor is 23" wide x 16 1/2" deep x 31" high (585 x 420 x 790 mm). You will need 4" (155 mm) above the pump and motor tank for servicing purposes.

One PVC sleeve, at least 4" (105 mm) in diameter, will be required between the hoistway and the machinery for the hydraulic hose and electrical conduit. This is to enable the installers to make the connection between the cylinder and the pumping unit. The sleeves should enter the hoistway at either corner of the support wall.

Please contact your local Garaventa Lift representative for specific local code requirements.

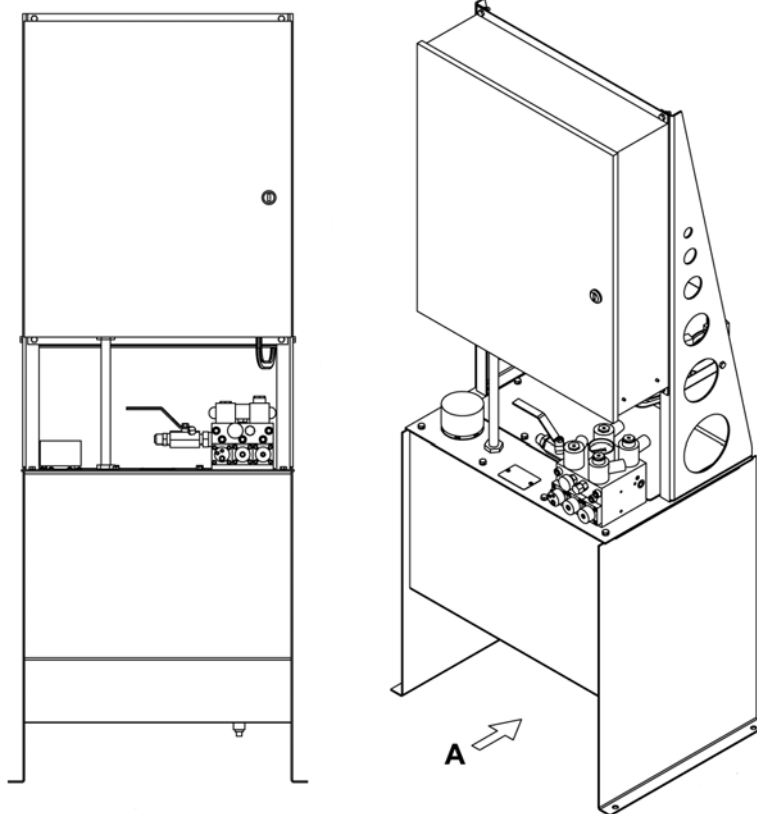

VIEW - A

Lighting

You must provide at least 100 lx lighting over the pumping unit and disconnect switches.

Electrical Disconnects

In the machine room, you will need to provide two separate lockable fused disconnects – one 15 amp for lighting and one 30 amp for the pumping unit. Disconnect switches should be located on the lock jamb side of the machine room door. In accordance to the electrical code, you must provide a minimum of 36" (915 mm) square in the US and 39 3/8" (1000 mm) square in Canada of working space in front of each disconnect switch.

The fused disconnect switch rating and fuse rating for the lift will be shown on the shop drawings for your project.

At least one GFCI duplex receptacle connected to a dedicated 15 amp branch circuit must be installed in the machine room.

Ventilation Requirements

No special requirements needed. The elevator pump unit will generate approximately 3200 BTU per hour under normal operating conditions. Recommended temperature for elevator equipment is 50° – 90° F (15° – 32° C) and 5% – 90% non-condensing. Please contact your local Garaventa Lift representative for possible local code variations.

Mains Power Requirements

The standard motor on the pump unit is 3 HP and it can be ordered to suit either single or three phase power.

- 230 VAC Single phase 30 amps
- 208 VAC Three phase 20 amps

Lighting Power Requirements

- 120 VAC Single phase 15 amps

Emergency Battery Lowering

In case of a power outage the elevator is provided with a second power source that allows the car to be lowered to the lowest landing. While descending, the car can stop and the passenger can exit the car at any landing along the way.

Emergency Manual Lowering

The elevator can be manually lowered from the release valve located on the top of the Control assembly tank.



Electrical Disconnects

Drive System - Machine Room & Electrical Requirements

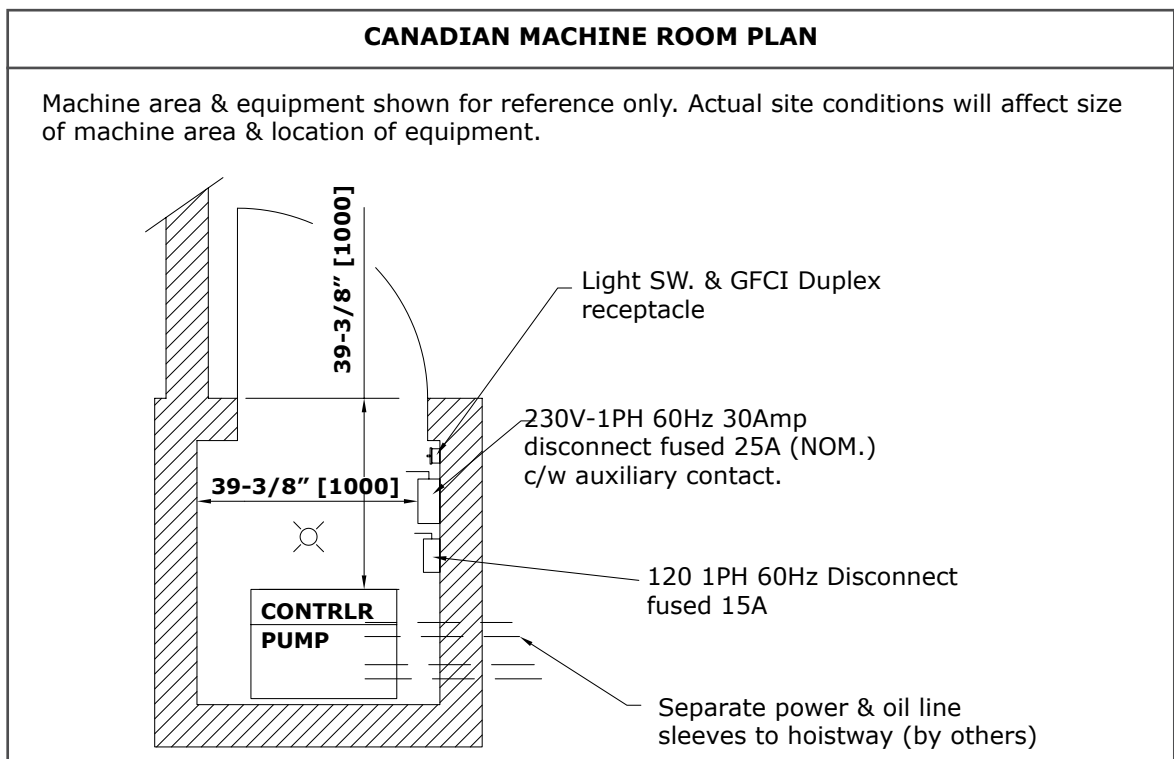
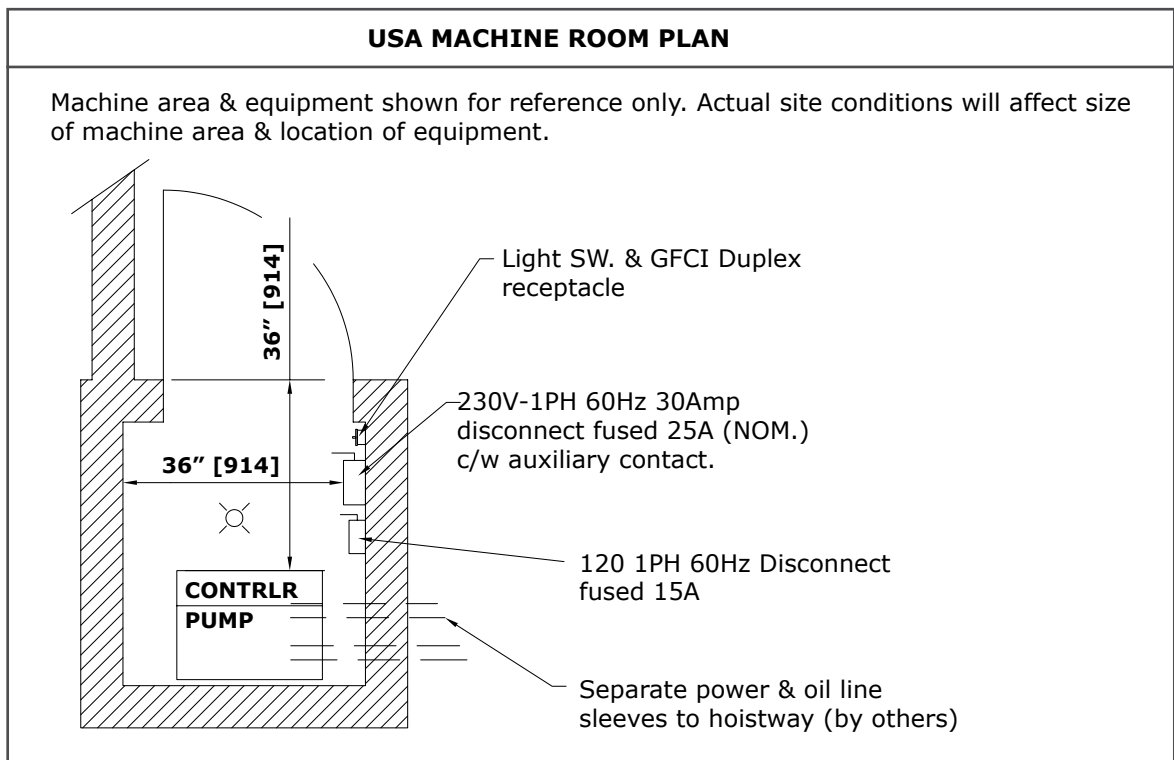

***Please contact your local Garaventa Lift representative for specific Machine Room Code Requirements.**

In-line Drive System Overview:

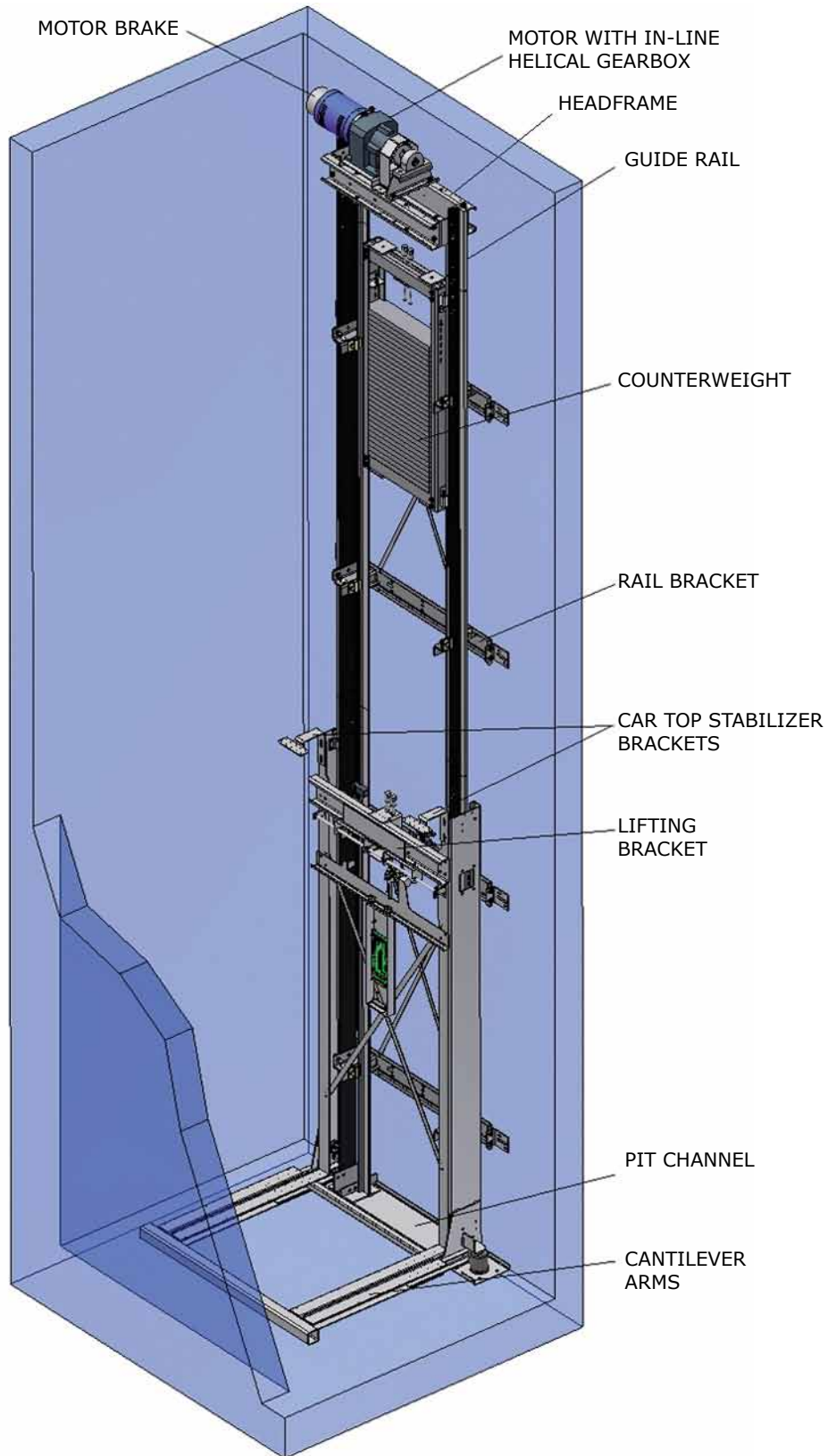

In-line Drive System - Technical Reference:

General

- Capacity - 750 lbs, 1000 lbs optional
- 40' (12.2 M) per minute nominal car speed
- Up to 6 stops, Maximum 6 landing doors
- Maximum floor total travel of 50' (15240 mm)
- Pit depth of 8" (200 mm) is recommended
- Overhead clearance of 96" (2440 mm) from upper landing with standard 84" (2135 mm) cab. 12" (305 mm) of extra overhead must be added to locate the electrical control box at the top of the rails
- Minimum distance between floors is 10" (255 mm)

Equipment

- Variable frequency drive for smooth start and stop
- Two #60 ANSI Roller Chain Suspension
- Heavy duty cantilever design utilizing 8 lbs per foot steel elevator guide rail system
- High Efficiency Helical reduction gear
- Standard power supply is 230 VAC single phase – 60/50 Hz

Controls

- Collective automatic operation with illuminated push buttons
- PLC (Programmable Logic Controller) with backup system for lights, locks, gate and/or door operator(s) where equipped
- Digital position indicator in cab
- Automatic cab lighting
- Emergency stop and alarm

Safety Features

- Emergency manual lowering
- Slack/broken chain instantaneous safety device
- Upper and Lower terminal limit switches and a Final limit at top and bottom of travel
- Hoistway door interlocks ensure the car does not move unless all hall doors and cab gate(s) are closed and locked
- Emergency light and alarm
- UL and/or CSA certified electrical control system
- Solid cab gate(s) with safety switch
- Mechanical Overspeed Governor with electronic detection
- Car and Counterweight Over Travel Bumpers
- Mechanically integrated fail safe brake system

Options

- Keyed hall stations
- Recessed telephone box or integrated telephone in cab control panel
- Automatic cab gate operator
- Automatic hoistway door operator
- Custom cab sizes and cab heights
- Emergency Battery Lowering
- Emergency Battery Back up

In-line Drive System - Electrical Control Box

With the In-line Drive the Electrical Control box can be located inside or outside the hoistway. When placed within the hoistway it is mounted on the wall next to the motor at the top of the rail system. Locating the Control box outside of the hoistway provides better access for installation and servicing.

If located inside the hoistway, the electrical control box will require 12" (305mm) of extra overhead clearance, distance from the upper landing level to the ceiling of the hoistway. The electrical control box, if located remotely must be within 50' (15.2 M) of the motor at the top of the hoistway.

Controller located at the top of the hoistway:

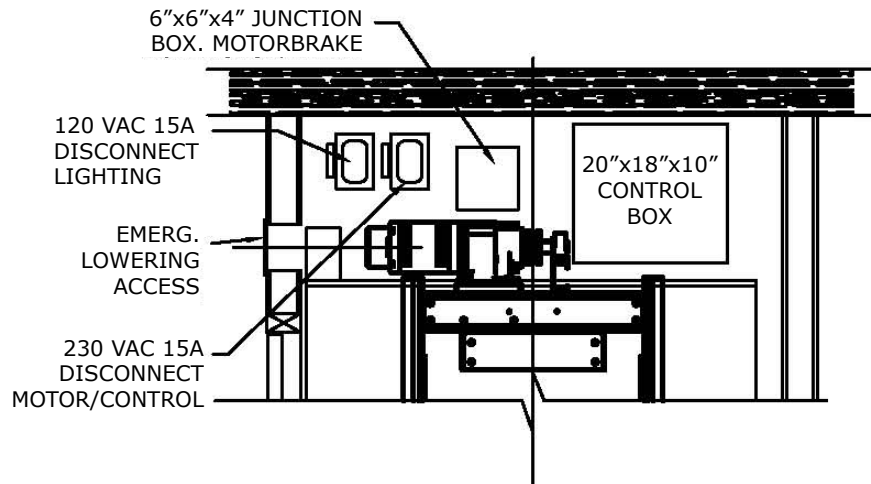

Controller located outside the hoistway:

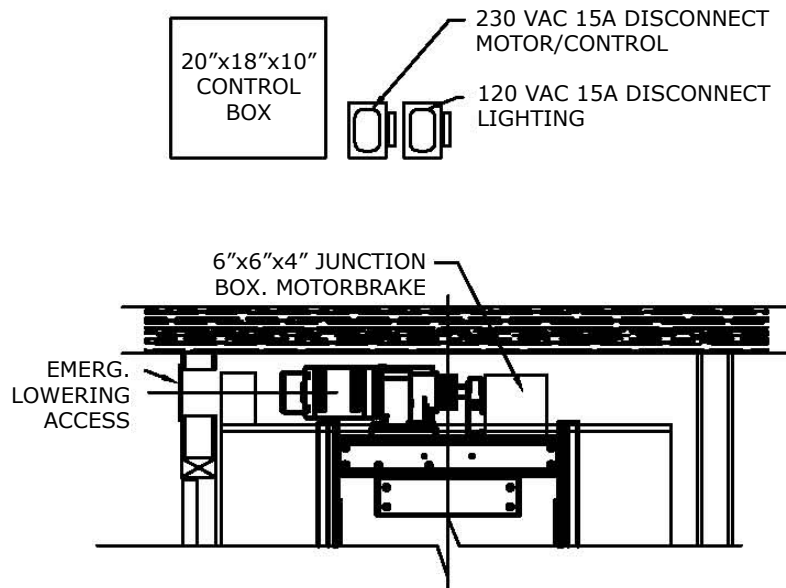

Note: Left hand motor shown

In-line Drive System - Electrical Control Box Details

Electrical Disconnects

Two separate 15 amp lockable fused disconnects are required and they must be located within reach of the electrical control box. One is for lighting and one will be for the control box.

In accordance with the electrical code, you must provide a minimum of 36" (915 mm) x 36" (915 mm) x 39^{3/8}" (1000mm) in the US and 39 3/8" (1000 mm) in Canada of working space in front of each disconnect switch and control box.

Specific requirements for the fused disconnect switch and fuse rating of your elevator will be shown on the shop drawings.



Electrical Disconnects

Ventilation Requirements

No special requirements needed. The elevator drive unit will generate approximately 3200 BTU per hour under normal operating conditions. Recommended temperature for elevator equipment is 50° – 90° F (15° – 32° C) and 5% – 90% non-condensing. Please contact your local Garaventa Lift representative for possible local code variations.

Mains Power Requirements

- 230 VAC Single phase 15 amps 60/50 Hz

Lighting Power Requirements

- 120 VAC Single phase 15 amps

Battery Lowering – Optional

In case of a power outage this optional feature allows the car to be lowered making stops at desired floors on its way.

Battery Backup – Optional

This feature ensures that the elevator continues to operate during a power outage. The self contained auxiliary power source is housed within a cabinet and can be located up to 15' (4.5 M) away from the control box.

Cabinet Size: 23 1/2" high x 17 1/2" wide x 7 5/8" deep (600 x 445 x 195 mm)

Emergency Lowering - Standard

The cab can be manually lowered in case of emergency, by inserting a handwheel into the end of the motor (and turned) to lower the cab. The elevator must be turned off either through the electrical disconnect or the home's main electrical panel before the elevator cab be lowered.

To insert this handwheel a small access door must be located at the upper landing. The access door is

supplied by Garaventa Lift and installed by others. The keyed white painted Access Door will be flush mounted in the wall.

Dimensions:

- Access door 5 1/8" x 5 1/8" (130 x 130 mm)
- Outside cover plate 8" x 9 1/2" (203 x 240 mm)
- Cut out in wall 6 1/2" x 6 1/2" (165 x 165 mm)

Emergency Lowering Access Door Location

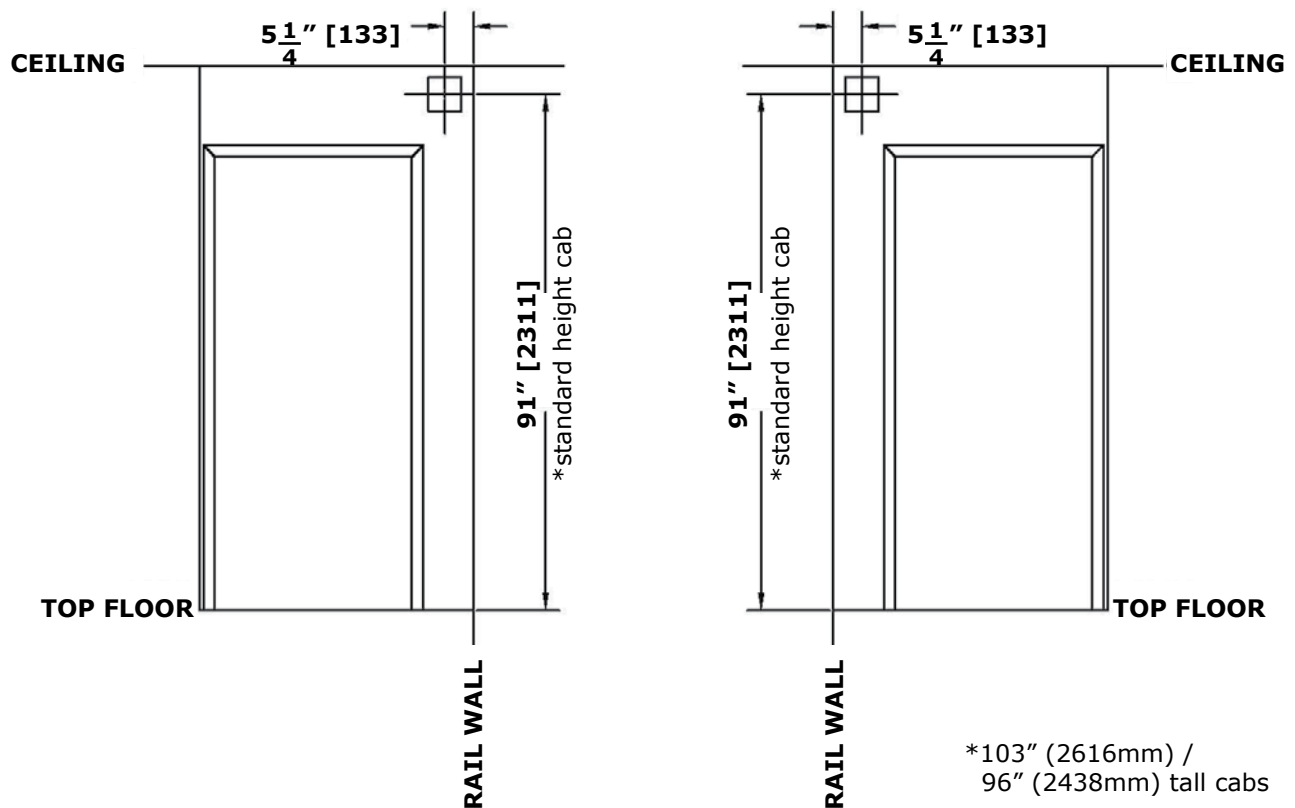

Note:

- Emergency Lowering Access Door locations shown in the drawing above are suitable for elevators with the upper landing door located adjacent to the rail wall.
- For elevators with the upper landing door not adjacent to the rail wall the Emergency Lowering Access Door must be located on the hoistway wall adjacent to the motor and not beside the upper door.
- Contact Garaventa Lift for more details.



Creating An Accessible World

 Printed in Canada
37086-H-DP

© Garaventa Lift. As we are continuously improving our products, specifications outlined in this brochure are subject to change without notice.

www.garaventalift.com

Authorized Garaventa Lift Representative